

NEW

maxon motor

Spindle Drive

Easy to configure spindle drive as a complete system.



Spindle Drive GP 22 S and GP 32 S

- with axial bearings for high axial loads
- compact design
- simple application
- configurable

maxon motor
driven by precision

Design

- ❶ Spindle, directly implemented in the gearhead
- ❷ Radial bearing
- ❸ Axial bearing
- ❹ Planetary gearhead 0 - 4 stages
- ❺ Motor
- ❻ Encoder

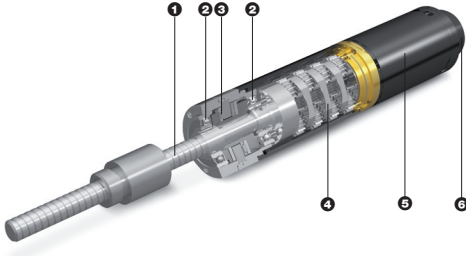

The particular type of spindle required must first be established before a spindle drive can be designed. Every type of spindle has different characteristics and a number of specific limits. These limits are taken into account in the technical data.

Ball screw:

- highly efficient
- not self-locking
- high load capacity

Metric spindle:

- self-locking
- low costs

Trapezoidal spindle:

- same as metric spindle
- higher load capacity than metric spindle

Feed force

For the calculation of the feed force acceleration and friction forces as well as gravity have to be taken into consideration. Exceeding the maximum permissible load must be avoided, as this damages the spindle. The maximum permissible feed force is displayed for standard spindles. For longer spindles, the permissible feed force can be limited by the critical compressive force of the spindle. In this case, supporting the end of the spindle may be necessary.

Limitation for ball screws

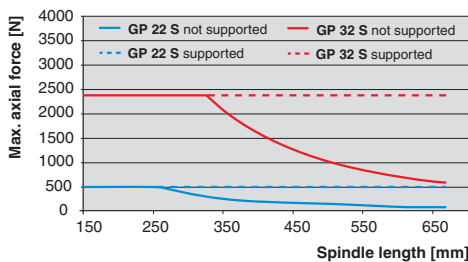

Torque

The required torque of the spindle M_a [mNm] is calculated with the feed force F_a [N] (load), the thread pitch p [mm] and the efficiency of the spindle η_1 .

$$M_a = \frac{F_a \cdot p}{2 \cdot \pi \cdot \eta_1}$$

In combination with the gearhead, the required motor torque M_{mot} [mNm] is:

$$M_{mot} = \frac{F_a \cdot p}{2 \cdot \pi \cdot i \cdot \eta}$$

Where i is the gearhead reduction ratio and η the efficiency of the complete spindle drive.

Technical Data

The "Technical Data" block contains generally applicable data on spindle, nut and gearhead. These are independent of the gearhead reduction ratio.

Length

The data sheets show the spindle drives with the standard lengths. Other lengths are available as an option in 5 mm steps up to a given maximum length. Please give detailed requirements for special lengths.

Max. efficiency / mass inertia

The values stated refer to the spindle alone (without gearhead). The values with gearhead are given in the „Gearhead data“ main data field.

Nut

Standard spindle drives are supplied with a thread nut. Flange or cylinder nuts are also available as an option. See details with corresponding reference number on page 8.

Bearing

The output stage and the spindle are supported by preloaded axial bearings. This means that the high axial forces can be absorbed directly by the gearhead without additional support.

Speed and feed velocity

Feed velocity v [m/s] is linked to output speed n [rpm] by the pitch p [mm].

$$v = \frac{p \cdot n}{60}$$

In combination with the gearhead, the motor speed n_{mot} [rpm] is:

$$n_{mot} = \frac{v \cdot 60 \cdot i}{p}$$

Where i is the gearhead reduction ratio and p the spindle pitch.

The spindle speed is limited by the resonance frequency of the spindle and for ball screws additionally by the ball return system.

Max. spindle speed at ball screws

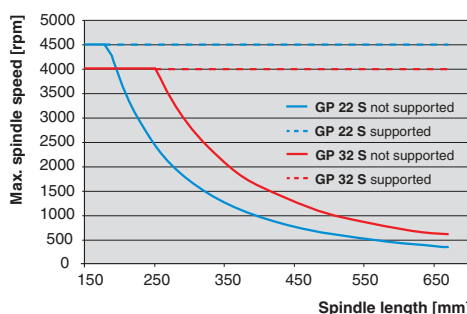

In addition, the maximum permissible speed of the gearhead has to be considered.

Spindle Drive Data

Reduction ratio

The reduction ratio indicates the ratio by which the speed of the spindle is lower than the motor speed.

Absolute reduction ratio

Provides the reduction ratio as an exact ratio of two integers.

Max. feed force (continuous)

Is the maximum permissible feed force which may be continuously applied. Exceeding this value results in a reduced service life.

Max. feed force (intermittent)

Is the maximum permissible feed force which may be intermittently applied. „Intermittently“ is defined as follows:

- during max. 1 second
- during max. 10% of operation

Exceeding these values results in a reduced service life.

Max. efficiency

The given efficiency is a maximum value that applies when loaded with maximum feed force. Efficiency falls sharply with very small loads. The stated value refers to the complete spindle drive (gearhead and spindle).

Mechanical positioning accuracy

In this value, following factors are taken in consideration:

- backlash of the gearhead
- accuracy of the spindle
- axial play of the nut

Maximum stroke

The maximum possible stroke depends on the length of the spindle L [mm]. The length of the nut L_N [mm] and the thickness of its mounting plate X [mm] must be taken in consideration.

$$Stroke = L - (L_N + X + stroke\ reserve)$$

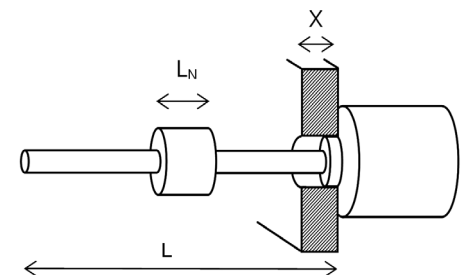

Mounting and safety instructions

Using a ball screw with a flange nut, the mounting through a hole is only possible with the optional rectangular mounting flange.

The ball screw nut may never be removed. As the balls are preloaded remounting would be impossible.

The spindle may never block during operation, as this could damage the spindle nut or gearhead.

Spindle Drive GP 22 S Ø22 mm, ball screw

NEW

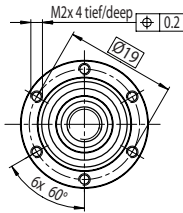
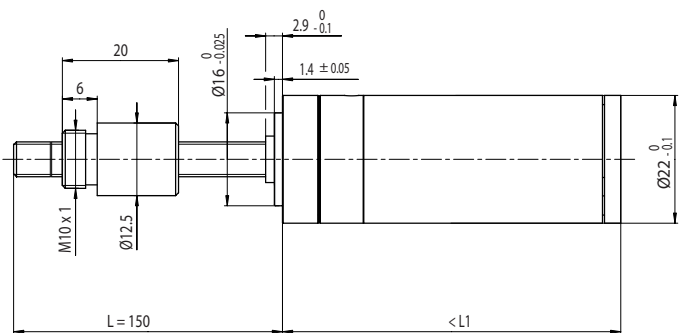

Options on page 8

Technical Data

Spindle	Ø6 x 2, stainless steel
Standard length	150 mm
Special length (5 mm steps)	max. 300 mm
Max. efficiency	96%
Mass inertia	1 gcm ²
Nut (standard)	thread nut
Material	100CR6, hardened
Axial play	< 0.01 mm
Planetary gearhead	straight teeth
Bearing	ball bearing / thrust roller bearing
Radial play, 5 mm from flange	< 0.05 mm
Axial play	preloaded
Recommended input speed ⁴	< 8000 rpm
Recommended temperature range	-15 ... +80°C
Max. radial load, 15 mm from flange	150 N
Max. axial load (static) ¹	500 N

- Stock program
- Standard program
- Special program (on request)

Order Number

	363863	363867	363871	363872	363877	363882	363887	363892
Spindle Drive Data (provisional)								
1 Reduction	1 : 1	14 : 1	29 : 1	53 : 1	89 : 1	198 : 1	333 : 1	479 : 1
2 Reduction absolute	$\frac{1}{1}$	$\frac{225}{16}$	$\frac{729}{25}$	$\frac{3375}{64}$	$\frac{4617}{52}$	$\frac{50625}{256}$	$\frac{69255}{208}$	$\frac{124659}{260}$
3 Max. feed velocity ¹	150	19	9.2	5.0	3.0	1.3	0.8	0.6
4 Max. feed force (continuous) ¹	N 77	154	196	240	285	372	443	500
5 Max. feed force (intermittent) ¹	N 183	365	465	500	500	500	500	500
Order Number								
1 Reduction	3.8 : 1	16 : 1		62 : 1	104 : 1	231 : 1	370 : 1	561 : 1
2 Reduction absolute	$\frac{15}{4}$	$\frac{885}{52}$		$\frac{12825}{208}$	$\frac{87723}{645}$	$\frac{192375}{632}$	$\frac{10556001}{28561}$	$\frac{2521}{4225}$
3 Max. feed velocity ¹	70	17		4.3	2.6	1.2	0.7	0.5
4 Max. feed force (continuous) ¹	N 100	161		253	300	392	458	500
5 Max. feed force (intermittent) ¹	N 236	381		500	500	500	500	500
Order Number								
1 Reduction	4.4 : 1	19 : 1		72 : 1	109 : 1	270 : 1	389 : 1	590 : 1
2 Reduction absolute	$\frac{57}{13}$	$\frac{3249}{169}$		$\frac{48735}{676}$	$\frac{2187}{20}$	$\frac{731025}{2704}$	$\frac{263189}{676}$	$\frac{59049}{100}$
3 Max. feed velocity ¹	61	14		3.7	2.4	1.0	0.7	0.5
4 Max. feed force (continuous) ¹	N 105	170		266	305	413	466	500
5 Max. feed force (intermittent) ¹	N 248	404		500	500	500	500	500
Order Number								
1 Reduction	5.4 : 1	20 : 1		76 : 1	128 : 1	285 : 1	410 : 1	690 : 1
2 Reduction absolute	$\frac{27}{5}$	$\frac{81}{4}$		$\frac{1215}{16}$	$\frac{41553}{325}$	$\frac{18225}{64}$	$\frac{6551}{16}$	$\frac{1121931}{1625}$
3 Max. feed velocity ¹	49	13		3.5	2.1	0.9	0.7	0.4
4 Max. feed force (continuous) ¹	N 112	173		270	322	420	474	500
5 Max. feed force (intermittent) ¹	N 266	411		500	500	500	500	500
Order Number								
1 Reduction		24 : 1		84 : 1	157 : 1	316 : 1	455 : 1	850 : 1
2 Reduction absolute		$\frac{1539}{65}$		$\frac{185193}{2197}$	$\frac{19683}{125}$	$\frac{2777895}{8788}$	$\frac{500211}{10985}$	$\frac{531441}{625}$
3 Max. feed velocity ¹		11		3.2	1.7	0.8	0.6	0.3
4 Max. feed force (continuous) ¹		N 184		280	345	435	491	500
5 Max. feed force (intermittent) ¹		N 437		500	500	500	500	500
6 Number of stages	1	2	2	3	3	4	4	4
7 Max. efficiency gearhead incl. spindle	% 81 ²	67	67	57	57	47	47	47
8 Weight ¹	g 103	115	115	128	128	141	141	141
9 Average backlash no load	° 1.0	1.2	1.2	1.6	1.6	2.0	2.0	2.0
10 Mechanical positioning accuracy ¹	mm 0.039	0.040	0.040	0.042	0.042	0.044	0.044	0.044
11 Mass inertia gearhead incl. spindle ¹	gcm ² 1.0 ³	0.4	0.4	0.3	0.3	0.3	0.3	0.3
12 Gearhead length L1	mm 38.0	44.8	44.8	51.6	51.6	58.4	58.4	58.4

¹ based on Spindle length 150 mm (standard length)

² for reduction 1:1 = 96%

³ for reduction 1:1 = 10 gcm²

⁴ for reduction 1:1 = 4500 rpm



Combination

+ Motor	Page	+ Tacho / Brake	Page	Overall length [mm] = Motor length + gearhead length + (tacho / brake)							
A-max 19	107/108			64.2	71.0	71.0	77.8	77.8	84.6	84.6	84.6
A-max 19, 1.5 W	108	MR	255/256	69.3	76.1	76.1	82.9	82.9	89.7	89.7	89.7
A-max 19, 1.5 W	108	Enc 22	261	78.6	85.4	85.4	92.2	92.2	99.0	99.0	99.0
A-max 19, 1.5 W	108	MEnc 13	270	71.7	78.5	78.5	85.3	85.3	92.1	92.1	92.1
A-max 19, 2.5 W	109/110			66.8	73.6	73.6	80.4	80.4	87.2	87.2	87.2
A-max 19, 2.5 W	110	MR	255/256	71.1	77.9	77.9	84.7	84.7	91.5	91.5	91.5
A-max 19, 2.5 W	110	Enc 22	261	81.2	88.0	88.0	94.8	94.8	101.6	101.6	101.6
A-max 19, 2.5 W	110	MEnc 13	270	74.3	81.1	81.1	87.9	87.9	94.7	94.7	94.7
A-max 22	111-114			67.2	74.0	74.0	80.8	80.8	87.6	87.6	87.6
A-max 22	112/114	MR	255/256	72.2	79.0	79.0	85.8	85.8	92.6	92.6	92.6
A-max 22	112/114	Enc 22	261	81.6	88.0	88.0	95.2	95.2	102.0	102.0	102.0
A-max 22	112/114	MEnc 13	270	74.3	81.1	81.1	87.9	87.9	94.7	94.7	94.7
RE-max 21	137/138			64.2	71.0	71.0	77.8	77.8	84.6	84.6	84.6
RE-max 21, 3.5 W	138	MR	255/256	69.3	76.1	76.1	82.9	82.9	89.7	89.7	89.7
RE-max 21	139/140			66.8	73.6	73.6	80.4	80.4	87.2	87.2	87.2
RE-max 21, 6 W	140	MR	255/256	71.1	77.9	77.9	84.7	84.7	91.5	91.5	91.5
RE-max 24	141-144			67.2	74.0	74.0	80.8	80.8	87.6	87.6	87.6
RE-max 24	142/144	MR	255/256	72.2	79.0	79.0	85.8	85.8	92.6	92.6	92.6

Spindle Drive GP 22 S Ø22 mm, metric spindle

NEW

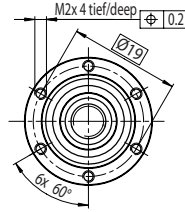
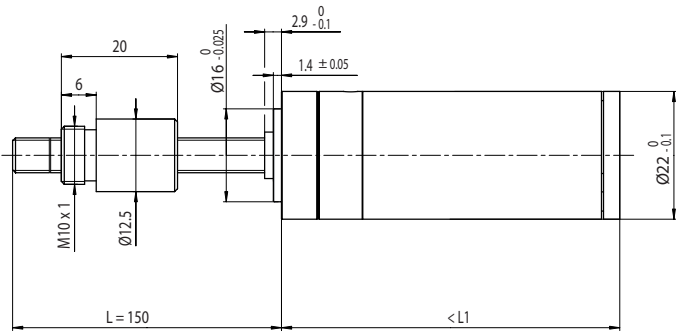

Options on page 8

Technical Data

Spindle	M6 x 1, stainless steel
Option	M6 x 1, ceramic
Standard length	150 mm
Special length (5mm steps)	max. 300 mm
Max. efficiency	41.6%
Mass inertia	1 gcm ²
Nut (standard)	thread nut
Material	CuSn12
Axial play	< 0.008 mm
Planetary gearhead	straight teeth
Bearing	ball bearing / thrust roller bearing
Radial play, 5 mm from flange	< 0.05 mm
Axial play	< 0.008 mm
Recommended input speed ⁴	< 8000 rpm
Recommended temperature range	-15 ... +80°C
Max. radial load, 15 mm from flange	150 N
Max. axial load (static) ¹	550 N

- Stock program
- Standard program
- Special program (on request)

Order Number

	363826	363830	363834	363835	363840	363845	363850	363855
Spindle Drive Data (provisional)								
1 Reduction	1 : 1	14 : 1	29 : 1	53 : 1	89 : 1	198 : 1	333 : 1	479 : 1
2 Reduction absolute	¹ / ₁	²²⁵ / ₁₆	⁷²⁹ / ₂₅	³³⁷⁵ / ₆₄	⁴⁶¹⁷ / ₅₂	⁵⁰⁶²⁵ / ₂₅₆	⁶⁹²⁵⁵ / ₂₀₈	¹²⁴⁶⁵⁹ / ₂₆₀
3 Max. feed velocity ¹	mm/s 101	9.5	4.6	2.5	1.5	0.7	0.4	0.3
4 Max. feed force (continuous) ¹	N 42	92	118	144	171	223	266	300
5 Max. feed force (intermittent) ¹	N 118	259	330	350	350	350	350	350
Order Number	363827	364040		363836	363841	363846	363851	363856
1 Reduction	3.8 : 1	16 : 1		62 : 1	104 : 1	231 : 1	370 : 1	561 : 1
2 Reduction absolute	¹⁵ / ₄	⁸⁸⁵ / ₅₂		¹²⁸²⁵ / ₂₀₈	⁸⁷⁷²³ / ₆₄₅	¹⁹²³⁷⁵ / ₈₃₂	¹⁰⁵⁵⁶⁰⁰¹ / ₂₈₅₆₁	²⁵²¹ / ₄₂₂₅
3 Max. feed velocity ¹	mm/s 35	8.3		2.2	1.3	0.6	0.4	0.2
4 Max. feed force (continuous) ¹	N 60	97		152	180	235	275	316
5 Max. feed force (intermittent) ¹	N 167	270		350	350	350	350	350
Order Number	363828	363831		363837	363842	363847	363852	363857
1 Reduction	4.4 : 1	19 : 1		72 : 1	109 : 1	270 : 1	389 : 1	590 : 1
2 Reduction absolute	⁵⁷ / ₁₃	³²⁴⁹ / ₁₆₉		⁴⁸⁷³⁵ / ₆₇₆	²¹⁸⁷ / ₂₀	⁷³¹⁰²⁵ / ₂₇₀₄	²⁸³¹⁸⁹ / ₆₇₆	⁵⁹⁰⁴⁹ / ₁₀₀
3 Max. feed velocity ¹	mm/s 30	7.0		1.9	1.2	0.5	0.3	0.2
4 Max. feed force (continuous) ¹	N 63	102		159	183	248	280	321
5 Max. feed force (intermittent) ¹	N 176	286		350	350	350	350	350
Order Number	363829	363832		363838	363843	363848	363853	363858
1 Reduction	5.4 : 1	20 : 1		76 : 1	128 : 1	285 : 1	410 : 1	690 : 1
2 Reduction absolute	²⁷ / ₅	⁸¹ / ₄		¹²¹⁵ / ₁₆	⁴¹⁵⁵³ / ₃₂₅	¹⁸²²⁵ / ₆₄	⁶⁵⁶¹ / ₁₆	¹¹²¹⁹³¹ / ₁₆₂₅
3 Max. feed velocity ¹	mm/s 25	6.7		1.8	1.0	0.5	0.3	0.2
4 Max. feed force (continuous) ¹	N 67	104		162	193	252	285	339
5 Max. feed force (intermittent) ¹	N 188	291		350	350	350	350	350
Order Number		363833		363839	363844	363849	363854	363859
1 Reduction		24 : 1		84 : 1	157 : 1	316 : 1	455 : 1	850 : 1
2 Reduction absolute		¹⁵³⁹ / ₆₅		¹⁸⁵¹⁹³ / ₂₁₉₇	¹⁹⁶⁸³ / ₁₂₅	²⁷⁷⁷⁸⁹⁵ / ₈₇₈₈	⁵⁰⁰⁰²¹¹ / ₁₀₉₈₅	⁵³¹⁴⁴¹ / ₆₂₅
3 Max. feed velocity ¹	mm/s	5.6		1.6	0.8	0.3	0.3	0.2
4 Max. feed force (continuous) ¹	N	111		168	207	261	295	350
5 Max. feed force (intermittent) ¹	N	310		350	350	350	350	350
6 Number of stages	1	2	2	3	3	4	4	4
7 Max. efficiency gearhead incl. spindle	%	35 ²	29	29	25	20	20	20
8 Weight ¹	g	103	116	116	128	128	141	141
9 Average backlash no load	°	1.0	1.2	1.2	1.6	1.6	2.0	2.0
10 Mechanical positioning accuracy ¹	mm	0.034	0.034	0.034	0.034	0.034	0.037	0.037
11 Mass inertia gearhead incl. spindle ¹	gcm ²	1.0 ³	0.4	0.4	0.3	0.3	0.3	0.3
12 Gearhead length L1	mm	38.0	44.8	44.8	51.6	51.6	58.4	58.4

¹ based on Spindle length 150 mm (standard length) ² for reduction 1:1 = 42% ³ for reduction 1:1 = 10 gcm² ⁴ for reduction 1:1 = 6088 rpm



Combination

+ Motor	Page	+ Tacho / Brake	Page	Overall length [mm] = Motor length + gearhead length + (tacho / brake)							
EC 16, 40 W	157			94.3	101.1	101.1	107.9	107.9	114.7	114.7	114.7
EC 16, 40 W	157		257	105.0	111.8	111.8	118.6	118.6	125.4	125.4	125.4
EC 22, 20 W	159			82.6	89.4	89.4	96.2	96.2	103.0	103.0	103.0
EC 22, 20 W	159	MR	257	88.6	95.4	95.4	102.2	102.2	109.0	109.0	109.0
EC 22, 20 W	160			87.6	94.4	94.4	101.2	101.2	108.0	108.0	108.0
EC 22, 50 W	161			100.8	107.6	107.6	114.0	114.0	121.2	121.2	121.2
EC 22, 50 W	161	MR	257	106.8	113.6	113.6	120.4	120.4	127.2	127.2	127.2
EC 22, 20 W	162			105.8	112.6	112.6	119.4	119.4	126.2	126.2	126.2
EC-max 16, 8 W	175			71.3	78.1	78.1	84.9	84.9	91.7	91.7	91.7
EC-max 16, 8 W	175	MR	257	78.6	85.4	85.4	92.2	92.2	99.0	99.0	99.0
EC-max 22, 12 W	176			70.1	76.9	76.9	83.7	83.7	90.5	90.5	90.5
EC-max 22, 12 W	176	MR	257	79.8	86.6	86.6	93.4	93.4	100.2	100.2	100.2
EC-max 22, 12 W	176	AB 20	306	106.6	113.4	113.4	120.2	120.2	127.0	127.0	127.0

Spindle Drive GP 32 S Ø32 mm, ball screw

NEW

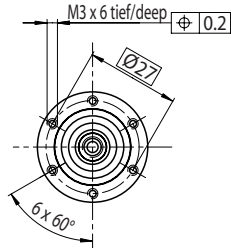
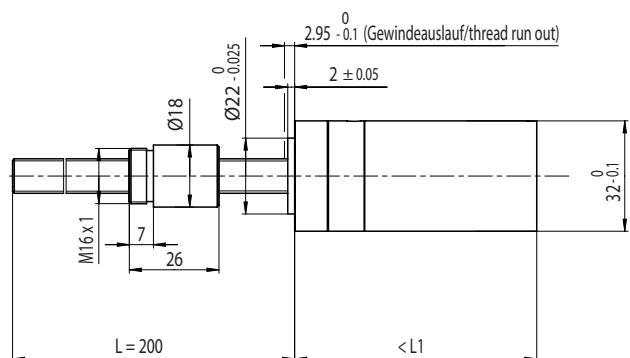

Options on page 8

Technical Data

Spindle	Ø10 x 2, stainless steel
Standard length	200 mm
Special length (5 mm steps)	max. 600 mm
Max. efficiency	94%
Mass inertia	9 gcm ²
Nut (standard)	thread nut
Material	100CR6, hardened
Axial play	< 0.01 mm
Planetary gearhead	straight teeth
Bearing	ball bearing / thrust roller bearing
Radial play, 5 mm from flange	< 0.05 mm
Axial play	preloaded
Recommended input speed ⁴	< 8000 rpm
Recommended temperature range	-15 ... +80°C
Max. radial load, 15 mm from flange	200 N
Max. axial load (static) ¹	2700 N

- Stock program
- Standard program
- Special program (on request)

Order Number

Spindle Drive Data (provisional)	363970	363974	363979	363980	363985	363990	363995	364000
1 Reduction	1 : 1	14 : 1	33 : 1	51 : 1	111 : 1	246 : 1	492 : 1	762 : 1
2 Reduction absolute	$\frac{1}{1}$	$\frac{676}{49}$	$\frac{529}{16}$	$\frac{17576}{343}$	$\frac{13824}{125}$	$\frac{421824}{1715}$	$\frac{86112}{175}$	$\frac{18044}{25}$
3 Max. feed velocity ¹	mm/s 133	19	8.1	5.2	2.4	1.1	0.5	0.3
4 Max. feed force (continuous) ¹	N 386	739	983	1137	1473	1921	2420	2700
5 Max. feed force (intermittent) ¹	N 1023	1956	2604	2700	2700	2700	2700	2700
Order Number	363971	363975		363981	363986	363991	363996	364001
1 Reduction	3.7 : 1	18 : 1		66 : 1	123 : 1	295 : 1	531 : 1	913 : 1
2 Reduction absolute	$\frac{26}{7}$	$\frac{624}{35}$		$\frac{16224}{245}$	$\frac{6877}{56}$	$\frac{101062}{343}$	$\frac{331776}{625}$	$\frac{36501}{40}$
3 Max. feed velocity ¹	mm/s 72	15		4.0	2.2	0.9	0.5	0.3
4 Max. feed force (continuous) ¹	N 474	803		1239	1524	2041	2482	2700
5 Max. feed force (intermittent) ¹	N 1255	2127		2700	2700	2700	2700	2700
Order Number	363972	363976		363982	363987	363992	363997	364002
1 Reduction	4.8 : 1	21 : 1		79 : 1	132 : 1	318 : 1	589 : 1	1093 : 1
2 Reduction absolute	$\frac{24}{5}$	$\frac{299}{14}$		$\frac{3887}{49}$	$\frac{3312}{25}$	$\frac{389376}{1225}$	$\frac{20631}{35}$	$\frac{279841}{256}$
3 Max. feed velocity ¹	mm/s 56	13		3.4	2.0	0.8	0.5	0.2
4 Max. feed force (continuous) ¹	N 517	846		1315	1561	2092	2569	2700
5 Max. feed force (intermittent) ¹	N 1369	2239		2700	2700	2700	2700	2700
Order Number	363973	363977		363983	363988	363993	363998	
1 Reduction	5.8 : 1	23 : 1		86 : 1	159 : 1	411 : 1	636 : 1	
2 Reduction absolute	$\frac{23}{4}$	$\frac{576}{25}$		$\frac{14976}{175}$	$\frac{1587}{10}$	$\frac{359424}{675}$	$\frac{79488}{125}$	
3 Max. feed velocity ¹	mm/s 46	12		3.1	1.7	0.6	0.4	
4 Max. feed force (continuous) ¹	N 551	872		1353	1661	2279	2636	
5 Max. feed force (intermittent) ¹	N 1458	2308		2700	2700	2700	2700	
Order Number		363978		363984	363989	363994	363999	
1 Reduction		28 : 1		103 : 1	190 : 1	456 : 1	706 : 1	
2 Reduction absolute		$\frac{138}{5}$		$\frac{3588}{35}$	$\frac{12167}{64}$	$\frac{89401}{196}$	$\frac{15817}{224}$	
3 Max. feed velocity ¹	mm/s	9.5		2.6	1.4	0.6	0.4	
4 Max. feed force (continuous) ¹	N	931		1437	1762	2359	2700	
5 Max. feed force (intermittent) ¹	N	2465		2700	2700	2700	2700	
6 Number of stages		1	2	2	3	3	4	4
7 Max. efficiency gearhead incl. spindle	%	75 ²	71	71	66	66	56	56
8 Weight ¹	g	304	331	331	359	359	387	387
9 Average backlash no load	°	0.7	0.8	0.8	1.0	1.0	1.0	1.0
10 Mechanical positioning accuracy ¹	mm	0.037	0.037	0.037	0.039	0.039	0.039	0.039
11 Mass inertia gearhead incl. spindle ¹	gcm ²	4.2	0.9	0.9	0.7	0.7	0.7	0.7
12 Gearhead length L1	mm	50.2	56.9	56.9	63.6	63.6	70.3	70.3

¹ based on Spindle length 200 mm (standard length) ² for reduction 1:1 = 94% ³ for reduction 1:1 = 42.3 gcm² ⁴ for reduction 1:1 = 4000 rpm



Combination

+ Motor	Page	+ Tacho / Brake	Page	Overall length [mm] = Motor length + gearhead length + (tacho / brake)							
RE 25, 10 W	77			104.8	111.5	111.5	118.2	118.2	124.9	124.9	124.9
RE 25, 10 W	77	MR	258	115.8	122.5	122.5	129.2	129.2	135.9	135.9	135.9
RE 25, 10 W	77	Enc 22	260	118.9	125.6	125.6	132.3	132.3	139.0	139.0	139.0
RE 25, 10 W	77	HED_5540	262/264	125.6	132.3	132.3	139.0	139.0	145.7	145.7	145.7
RE 25, 10 W	77	DCT 22	271	127.1	133.8	133.8	140.5	140.5	147.2	147.2	147.2
RE 25, 20 W	78			93.3	100.0	100.0	106.7	106.7	113.4	113.4	113.4
RE 25, 20 W	79			104.8	111.5	111.5	118.2	118.2	124.9	124.9	124.9
RE 25, 20 W	79	MR	258	115.8	122.5	122.5	129.2	129.2	135.9	135.9	135.9
RE 25, 20 W	79	Enc 22	260	118.9	125.6	125.6	132.3	132.3	139.0	139.0	139.0
RE 25, 20 W	79	HED_5540	262/264	125.6	132.3	132.3	139.0	139.0	145.7	145.7	145.7
RE 25, 20 W	79	DCT 22	271	127.1	133.8	133.8	140.5	140.5	147.2	147.2	147.2
RE 25, 20 W	79	HED_5540 1 AB 28	308	156.0	162.7	162.7	169.4	169.4	176.1	176.1	176.1
RE 26, 18 W	80			109.1	115.8	115.8	122.5	122.5	129.2	129.2	129.2
RE 26, 18 W	80	MR	258	120.1	126.8	126.8	133.5	133.5	140.2	140.2	140.2
RE 26, 18 W	80	Enc 22	260	126.5	133.2	133.2	139.9	139.9	146.6	146.6	146.6
RE 26, 18 W	80	HED_5540	262/264	127.5	134.2	134.2	140.9	140.9	147.6	147.6	147.6
RE 26, 18 W	80	DCT 22	271	130.1	136.8	136.8	143.5	143.5	150.2	150.2	150.2
RE 30, 60 W	81			115.1	125.0	125.0	131.7	131.7	138.4	138.4	138.4
RE 30, 60 W	81	MR	259	129.7	136.4	136.4	143.1	143.1	149.8	149.8	149.8
RE 35, 90 W	82			118.0	127.9	127.9	134.6	134.6	141.3	141.3	141.3
RE 35, 90 W	82	MR	259	132.6	139.3	139.3	146.0	146.0	152.7	152.7	152.7
RE 35, 90 W	82	HED_5540	262/264	142.2	148.9	148.9	155.6	155.6	162.3	162.3	162.3

Spindle Drive GP 32 S Ø32 mm, metric spindle

NEW

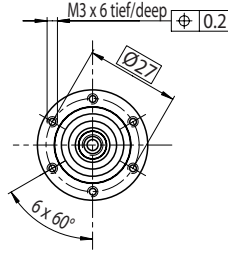
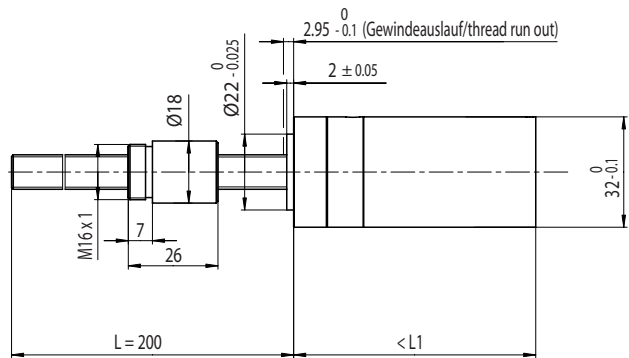

Options on page 8

Technical Data

Spindle	M10 x 1, stainless steel
Option	M10 x 1, ceramic
Standard length	200 mm
Special length (5mm steps)	max. 600 mm
Max. efficiency	27.0%
Mass inertia	9 gcm ²
Nut (standard)	thread nut
Material	CuSn12
Axial play	< 0.008 mm
Planetary gearhead	straight teeth
Bearing	ball bearing / thrust roller bearing
Radial play, 5 mm from flange	< 0.05 mm
Axial play	preloaded
Recommended input speed ⁴	< 8000 rpm
Recommended temperature range	-15 ... +80°C
Max. radial load, 15 mm from flange	200 N
Max. axial load (static) ¹	2700 N

- Stock program
- Standard program
- Special program (on request)

Order Number

Spindle Drive Data (provisional)	363900	363904	363909	363980	363910	363920	363925	363930
1 Reduction	1 : 1	14 : 1	33 : 1	51 : 1	111 : 1	246 : 1	492 : 1	762 : 1
2 Reduction absolute	¹ / ₁	⁶⁷⁶ / ₄₉	⁵²⁹ / ₁₆	¹⁷⁵⁷⁶ / ₃₄₃	¹³⁸²⁴ / ₁₂₅	⁴²¹⁸²⁴ / ₁₇₁₅	⁸⁶¹¹² / ₁₇₅	¹⁸⁰⁴⁴ / ₂₅
3 Max. feed velocity ¹	mm/s 100	9.5	4.0	2.6	1.2	0.5	0.3	0.2
4 Max. feed force (continuous) ¹	N 183	400	533	616	798	1040	1311	1350
5 Max. feed force (intermittent) ¹	N 455	995	1324	1350	1350	1350	1350	1350
Order Number	363901	363905		363911	363916	363921	363926	363931
1 Reduction	3.7 : 1	18 : 1		66 : 1	123 : 1	295 : 1	531 : 1	913 : 1
2 Reduction absolute	²⁶ / ₇	⁶²⁴ / ₃₅		¹⁶²²⁴ / ₂₄₅	⁶⁸⁷⁷ / ₅₆	¹⁰¹⁰⁶² / ₃₄₃	³³¹⁷⁷⁶ / ₆₂₅	³⁶⁵⁰¹ / ₄₀
3 Max. feed velocity ¹	mm/s 36	7.4		2.0	1.1	0.5	0.3	0.1
4 Max. feed force (continuous) ¹	N 257	435		671	826	1105	1345	1350
5 Max. feed force (intermittent) ¹	N 638	1082		1350	1350	1350	1350	1350
Order Number	363902	363906		363912	363917	363922	363927	363932
1 Reduction	4.8 : 1	21 : 1		79 : 1	132 : 1	318 : 1	589 : 1	1093 : 1
2 Reduction absolute	²⁴ / ₅	²⁹⁹ / ₁₄		³⁸⁸⁷ / ₄₉	³³¹² / ₂₅	³⁸⁹³⁷⁶ / ₁₂₂₅	²⁰⁶³¹ / ₃₅	²⁷⁹⁸⁴¹ / ₂₅₆
3 Max. feed velocity ¹	mm/s 28	6.3		1.7	1.0	0.4	0.2	0.1
4 Max. feed force (continuous) ¹	N 280	458		712	845	1133	1350	1350
5 Max. feed force (intermittent) ¹	N 696	1139		1350	1350	1350	1350	1350
Order Number	363903	363907		363913	363918	363923	363928	
1 Reduction	5.8 : 1	23 : 1		86 : 1	159 : 1	411 : 1	636 : 1	
2 Reduction absolute	²³ / ₄	⁵⁷⁶ / ₂₅		¹⁴⁹⁷⁶ / ₁₇₅	¹⁵⁸⁷ / ₁₀	³⁵⁹⁴²⁴ / ₆₇₅	⁷⁹⁴⁸⁸ / ₁₂₅	
3 Max. feed velocity ¹	mm/s 23	5.8		1.6	0.8	0.3	0.2	
4 Max. feed force (continuous) ¹	N 298	472		733	899	1234	1350	
5 Max. feed force (intermittent) ¹	N 742	1174		1350	1350	1350	1350	
Order Number		363908		363914	363919	363924	363929	
1 Reduction		28 : 1		103 : 1	190 : 1	456 : 1	706 : 1	
2 Reduction absolute		¹³⁸ / ₅		³⁵⁸⁸ / ₃₅	¹²¹⁶⁷ / ₆₄	⁸⁹⁴⁰¹ / ₁₉₆	¹⁵⁸¹⁷ / ₂₂₄	
3 Max. feed velocity ¹	mm/s	4.8		1.3	0.7	0.3	0.2	
4 Max. feed force (continuous) ¹	N	504		778	955	1278	1350	
5 Max. feed force (intermittent) ¹	N	1253		1350	1350	1350	1350	
6 Number of stages	1	2	2	3	3	4	4	4
7 Max. efficiency gearhead incl. spindle	%	22 ²	20	19	19	16	16	16
8 Weight ¹	g	304	331	331	359	359	387	387
9 Average backlash no load	°	0.7	0.8	0.8	1.0	1.0	1.0	1.0
10 Mechanical positioning accuracy ¹	mm	0.033	0.033	0.033	0.034	0.034	0.034	0.034
11 Mass inertia gearhead incl. spindle ¹	gcm ²	3.0	0.9	0.9	0.7	0.7	0.7	0.7
12 Gearhead length L1	mm	50.2	56.9	56.9	63.6	63.6	70.3	70.3

¹ based on Spindle length 200 mm (standard length) ² for reduction 1:1 = 27% ³ for reduction 1:1 = 43.3 gcm² ⁴ for reduction 1:1 = 4000 rpm



Combination

+ Motor	Page	+ Tacho / Brake	Page	Overall length [mm] = Motor length + gearhead length + (tacho / brake)							
RE 35, 90 W	82	DCT22	271	139.3	146.0	146.0	152.7	152.7	159.4	159.4	159.4
RE 35, 90 W	82	AB 28	308	157.3	164.0	164.0	170.7	170.7	177.4	177.4	177.4
RE 35, 90 W	82	HEDS 5540 ¹ /	262/308	174.4	181.1	181.1	187.8	187.8	194.5	194.5	194.5
RE 36, 70 W	83			121.5	128.2	128.2	134.9	134.9	141.6	141.6	141.6
RE 36, 70 W	83	MR	259	132.9	139.6	139.6	146.3	146.3	153.0	153.0	153.0
RE 36, 70 W	83	HED_ 5540	262/264	142.5	149.2	149.2	155.9	155.9	162.6	162.6	162.6
RE 36, 70 W	83	DCT22	271	139.6	146.3	146.3	153.0	153.0	159.7	159.7	159.7
A-max 26	115-122			95.0	101.7	101.7	108.4	108.4	115.1	115.1	115.1
A-max 26	115-121		270	102.1	108.8	108.8	115.5	115.5	122.2	122.2	122.2
A-max 26	116-122		254	103.8	110.5	110.5	117.2	117.2	123.9	123.9	123.9
A-max 26	116-122		260	109.4	116.1	116.1	122.8	122.8	129.5	129.5	129.5
A-max 26	116-122		262/264	113.8	120.5	120.5	127.2	127.2	133.9	133.9	133.9
A-max 32	123/125			113.2	119.9	119.9	126.6	126.6	133.3	133.3	133.3
A-max 32	124/126			111.8	118.5	118.5	125.2	125.2	131.9	131.9	131.9
A-max 32	124/126		255	123.0	129.7	129.7	136.4	136.4	143.1	143.1	143.1
A-max 32	124/126		262/264	132.6	139.3	139.3	146.0	146.0	152.7	152.7	152.7
RE-max 29	145-148			95.0	101.7	101.7	108.4	108.4	115.1	115.1	115.1
RE-max 29	146/148		254	103.8	110.5	110.5	117.2	117.2	123.9	123.9	123.9
EC 32, 80 W	164			110.3	117.0	117.0	123.7	123.7	130.4	130.4	130.4
EC 32, 80 W	164	HED_ 5540	262/264	128.7	135.4	135.4	142.1	142.1	148.8	148.8	148.8
EC 32, 80 W	164	Res 26	272	130.4	137.1	137.1	143.8	143.8	150.5	150.5	150.5

Spindle Drive GP 32 S Ø32 mm, trapezoidal spindle

NEW

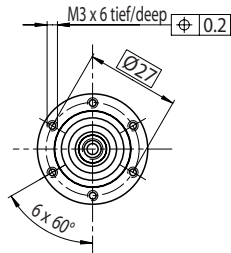
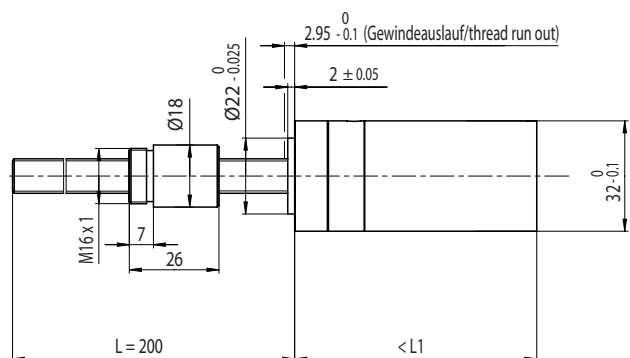

Options on page 8

Technical Data

Spindle	TP10 x 2, stainless steel
Standard length	200 mm
Special length (5 mm steps)	max. 600 mm
Max. efficiency	47.0%
Mass inertia	9 gcm ²
Nut (standard)	thread nut
Material	CuSn12
Axial play	< 0.008 mm
Planetary gearhead	straight teeth
Bearing	ball bearing / thrust roller bearing
Radial play, 5 mm from flange	< 0.05 mm
Axial play!	preloaded
Recommended input speed ⁴	< 8000 rpm
Recommended temperature range	-15 ... +80°C
Max. radial load, 15 mm from flange	200 N
Max. axial load (static) ¹	2700 N

- Stock program
- Standard program
- Special program (on request)

Order Number

	363936	363940	363945	363946	363951	363956	363961	363966
Spindle Drive Data (provisional)								
1 Reduction	1 : 1	14 : 1	33 : 1	51 : 1	111 : 1	246 : 1	492 : 1	762 : 1
2 Reduction absolute	$\frac{1}{1}$	$\frac{676}{49}$	$\frac{529}{16}$	$\frac{1757}{343}$	$\frac{13824}{125}$	$\frac{421824}{1715}$	$\frac{86112}{175}$	$\frac{18044}{25}$
3 Max. feed velocity ¹	186 mm/s	19	8.1	5.2	2.4	1.1	0.5	0.3
4 Max. feed force (continuous) ¹	N 216	462	614	710	921	1200	1512	1530
5 Max. feed force (intermittent) ¹	N 528	1127	1500	1530	1530	1530	1530	1530
Order Number	363937	363941		363947	363952	363957	363962	363967
1 Reduction	3.7 : 1	18 : 1		66 : 1	123 : 1	295 : 1	531 : 1	913 : 1
2 Reduction absolute	$\frac{26}{7}$	$\frac{624}{35}$		$\frac{16224}{245}$	$\frac{6877}{56}$	$\frac{101062}{343}$	$\frac{331776}{625}$	$\frac{36501}{40}$
3 Max. feed velocity ¹	72 mm/s	15		4.0	2.2	0.9	0.5	0.3
4 Max. feed force (continuous) ¹	N 296	502		774	953	1275	1530	1530
5 Max. feed force (intermittent) ¹	N 723	1226		1530	1530	1530	1530	1530
Order Number	363938	363942		363948	363953	363958	363963	363968
1 Reduction	4.8 : 1	21 : 1		79 : 1	132 : 1	318 : 1	589 : 1	1093 : 1
2 Reduction absolute	$\frac{24}{5}$	$\frac{299}{14}$		$\frac{3887}{49}$	$\frac{3312}{25}$	$\frac{389376}{1225}$	$\frac{20631}{35}$	$\frac{279841}{256}$
3 Max. feed velocity ¹	56 mm/s	13		3.4	2.0	0.8	0.5	0.2
4 Max. feed force (continuous) ¹	N 323	529		822	975	1308	1530	1530
5 Max. feed force (intermittent) ¹	N 789	1291		1530	1530	1530	1530	1530
Order Number	363939	363943		363949	363954	363959	363964	
1 Reduction	5.8 : 1	23 : 1		86 : 1	159 : 1	411 : 1	636 : 1	
2 Reduction absolute	$\frac{23}{4}$	$\frac{576}{25}$		$\frac{14976}{175}$	$\frac{1587}{10}$	$\frac{359424}{675}$	$\frac{79488}{125}$	
3 Max. feed velocity ¹	46 mm/s	12		3.1	1.7	0.6	0.4	
4 Max. feed force (continuous) ¹	N 344	545		846	1038	1424	1530	
5 Max. feed force (intermittent) ¹	N 840	1330		1530	1530	1530	1530	
Order Number		363944		363950	363955	363960	363965	
1 Reduction		28 : 1		103 : 1	190 : 1	456 : 1	706 : 1	
2 Reduction absolute		$\frac{138}{5}$		$\frac{3588}{35}$	$\frac{12167}{64}$	$\frac{89401}{196}$	$\frac{15817}{224}$	
3 Max. feed velocity ¹		9.5 mm/s		1.3	0.7	0.3	0.2	
4 Max. feed force (continuous) ¹		N 582		898	1101	1475	1530	
5 Max. feed force (intermittent) ¹		N 1420		1530	1530	1530	1530	
6 Number of stages	1	2	2	3	3	4	4	4
7 Max. efficiency gearhead incl. spindle	% 38 ²	35	35	33	33	28	28	28
8 Weight ¹	g 304	331	331	359	359	387	387	387
9 Average backlash no load	° 0.7	0.8	0.8	1.0	1.0	1.0	1.0	1.0
10 Mechanical positioning accuracy ¹	mm 0.035	0.035	0.035	0.037	0.037	0.037	0.037	0.037
11 Mass inertia gearhead incl. spindle ¹	gcm ² 2.4	0.9	0.9	1.0	1.0	1.0	1.0	1.0
12 Gearhead length L1	mm 50.2	56.9	56.9	63.6	63.6	70.3	70.3	70.3

¹ based on Spindle length 200 mm (standard length) ² for reduction 1:1 = 47% ³ for reduction 1:1 = 42.3 gcm² ⁴ for reduction 1:1 = 5569 rpm



Combination

+ Motor	Page	+ Tacho / Brake	Page	Overall length [mm] = Motor length + gearhead length + (tacho / brake)							
EC-max 22, 25 W	177			98.8	105.5	105.5	112.2	112.2	118.9	118.9	118.9
EC-max 22, 25 W	177	MR	253	108.5	115.2	115.2	121.9	121.9	128.6	128.6	128.6
EC-max 22, 25 W	177	AB 20	306	135.3	142.0	142.0	148.7	148.7	155.4	155.4	155.4
EC-max 30, 40 W	178			92.3	99.0	99.0	105.7	105.7	112.4	112.4	112.4
EC-max 30, 40 W	178	MR	255	104.5	111.2	111.2	117.9	117.9	124.6	124.6	124.6
EC-max 30, 40 W	178	HEDL5540	262	112.9	119.6	119.6	126.3	126.3	133.0	133.0	133.0
EC-max 30, 40 W	178	AB 20	306	124.4	131.1	131.1	137.8	137.8	144.5	144.5	144.5
EC-max 30, 40 W	178	HEDL 5540 I AB	262/306	149.3	156.0	156.0	162.7	162.7	169.4	169.4	169.4
EC-power 22, 90 W	185			98.9	155.6	105.6	112.3	112.3	119.0	119.0	119.0
EC-power 22, 120 W	186			116.3	123.0	123.0	129.7	129.7	136.4	136.4	136.4
MCD EPOS, 60 W	303			170.3	177.0	177.0	183.7	183.7	190.4	190.4	190.4
MCD EPOS P 60 W	303			170.3	177.0	177.0	183.7	183.7	190.4	190.4	190.4
EC-i 40, 50 W	199			81.8	88.5	88.5	95.2	95.2	101.9	101.9	101.9
EC-i 40, 50 W	199	MR	259	97.5	104.2	104.2	110.9	110.9	117.6	117.6	117.6
EC-i 40, 50 W	199	HEDL 5540	266	105.2	111.9	111.9	118.6	118.6	125.3	125.3	125.3
EC-i 40, 70 W	200			91.8	98.5	98.5	105.2	105.2	111.9	111.9	111.9
EC-i 40, 70 W	200	MR	259	107.5	114.2	114.2	120.9	120.9	127.6	127.6	127.6
EC-i 40, 70 W	2.00	HEDL 5540	266	115.2	121.9	121.9	128.6	128.6	135.3	135.3	135.3

Option	to GP 22 S	to GP 32 S
--------	------------	------------

Special length
Order reference SPIN01

Without specification, the spindle is supplied in the standard length 150 mm. Special lengths can be ordered in 5 mm steps up to the stated maximum length. Please specify the length you require when placing your order.

Without specification, the spindle is supplied in the standard length 200 mm. Special lengths can be ordered in 5 mm steps up to the stated maximum length. Please specify the length you require when placing your order.

Spindle end
Order reference SPIN02

In order to support the end of the spindle by an additional bearing, it can be delivered according to the illustration.

Customer specific spindle ends on request.

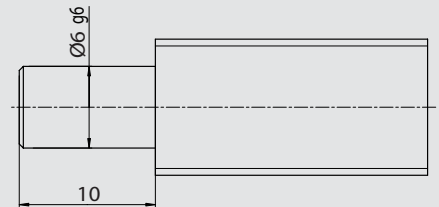
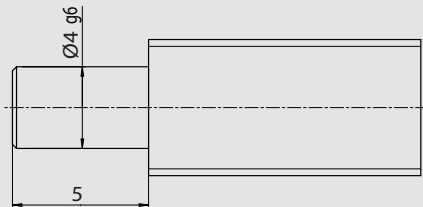

Cylinder nut
Order reference SPIN03

Cylinder nut instead of the standard thread nut.

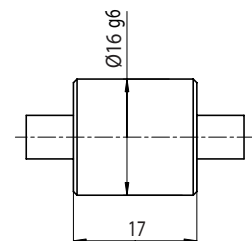
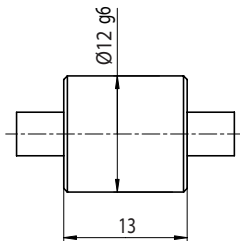

Flange nut
Order reference SPIN04

Flange nut instead of the standard thread nut.

If using a ball screw, the rectangular mounting flange (SPIN 05) must be used.

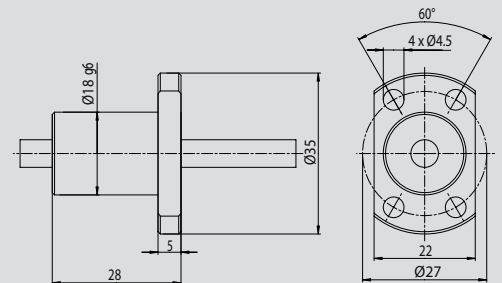
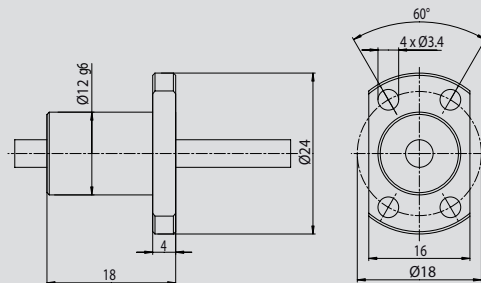

Low backlash ball screw nut
Order reference SPIN05

Axial play is almost eliminated through increased pre-loading of the ball screw nut. Although, the increased load can lead to greater wear.

Axial play is almost eliminated through increased pre-loading of the ball screw nut. Although, the increased load can lead to greater wear.

Rectangular mounting flange
Order reference SPIN06

Spindle drive with rectangular mounting flange allows mounting from the gearhead side.

If using a ball screw with flange nut, the rectangular assembly flange must be used for mounting.

