

Technology – short and to the point

Gears

If mechanical power is required at a high torque and correspondingly reduced speed, a maxon precision gear is recommended. According to the gear ratio the output speed is reduced while the output torque is enhanced. For a more precise determination of the latter, efficiency must be taken into consideration.

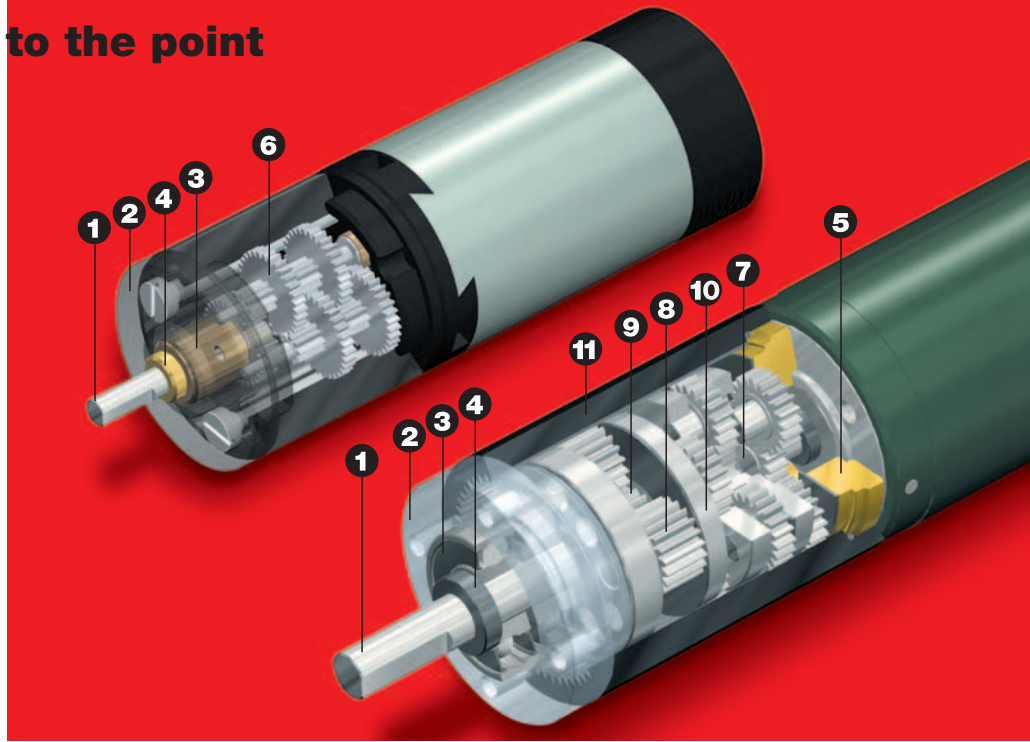

Spur gearhead

The gear consists of one or more stages. One stage represents the pairing of two cogwheels. The first cogwheel (pinion) is mounted directly on the motor shaft. The bearing of the output shaft is usually made of sintered material.

- Favorably priced
- For low torques
- Output torque up to 2 Nm
- Reduction ratios of 6 : 1 to 5752 : 1
- External - Ø12 - 45 mm
- Low noise level
- High efficiency

Planetary gearhead

Planetary gears are particularly suitable for the transfer of high torques. Large gearheads are normally fitted with ball bearings at gearhead output.

- For transferring high torques up to 180 Nm
- Reduction ratios of 4 : 1 to 6285 : 1
- External - Ø6 - 81 mm
- High performance in a small space
- High reduction ratio in a small space
- Concentric gear input and output

Spur gearhead

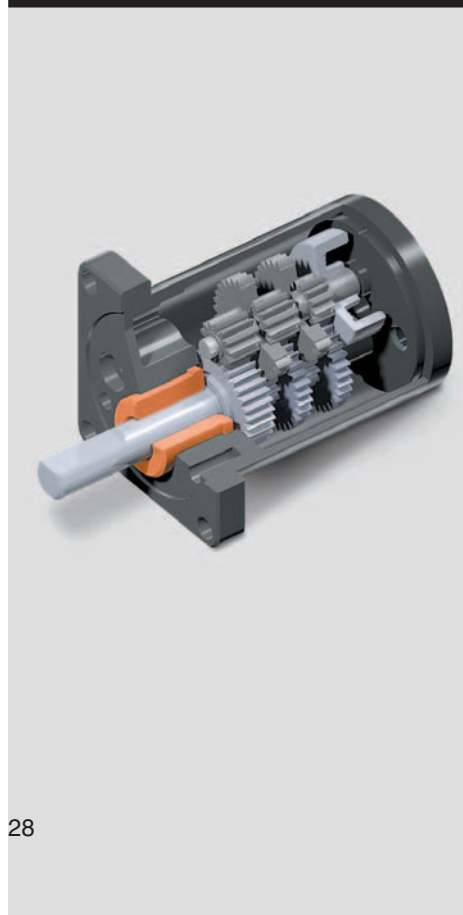

Planetary gearhead

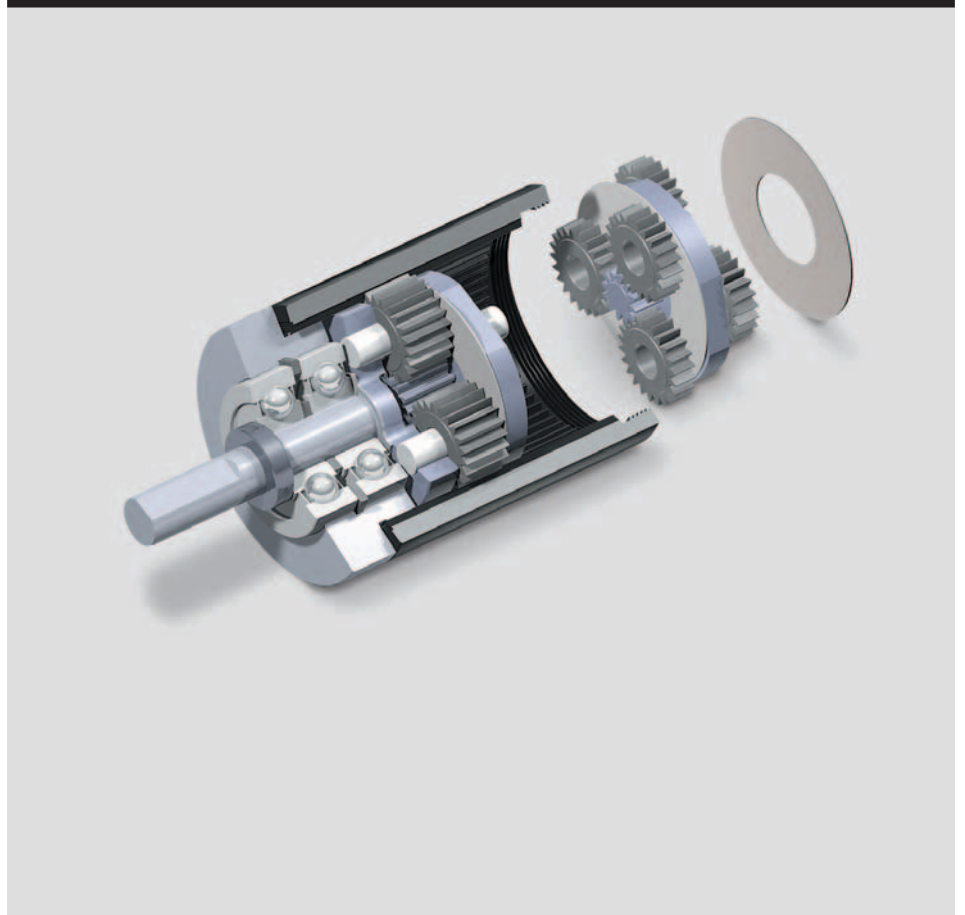

- 1 Output shaft
- 2 Mounting flange
- 3 Bearing of the output shaft
- 4 Axial security
- 5 Intermediate plate
- 6 Cogwheel
- 7 Motor pinion
- 8 Planetary gearwheel
- 9 Sun gearwheel
- 10 Planet carrier
- 11 Internal gear

Program

maxon gear

Planetary gearhead

Spur gearhead

Micro Harmonic Drive®

maxon gear

Conversion

The conversion of speed and torque of the gear output (n_B , M_B) to the motor shaft (n_{mot} , M_{mot}) follows the following equations:

$$n_{mot} = i \cdot n_B$$

$$M_{mot} = \frac{M_B}{i \cdot \eta_g}$$

where:

i : reduction

η_g : Gearhead efficiency

Selection of gears

As with motors, speed and torque limits also apply to gearheads. Operating torque must be below gearhead $M_{N,G}$ nominal torque (max. continuous torque).

$$M_{N,G} > M_B$$

With short-term loads, the intermittent torque of the gear should also be taken into consideration.

Note that the nominal torque (continuous torque) of the gear is dependent on the number of stages.

Where possible, the input speed of the gear $n_{max,g}$ should not be exceeded. This limits the maximum possible reduction i_{max} at a given operating speed. The following applies to the selection of the reduction i

$$i \leq i_{max} = \frac{n_{max,G}}{n_B}$$

If the gear is selected, the data converted to the motor axis (n_{mot} , M_{mot}) are used to select the motor. The maxon modular system defines the proper motor / gear combinations.

Service life

The gears usually achieve 1000 to 3000 operating hours in continuous operation at the maximum permissible load and recommended input speed.

The following have an influence:

- Exceeding maximum torque can lead to excessive wear.
- Local temperature peaks in the area of tooth contact can destroy the lubricant.
- Massively exceeding the gear input speed reduces the service life.
- Radial and axial loads on the bearing.

Temperature / lubrication

maxon gears are lubricated for life. The lubricants used are especially effective in the recommended temperature range. At higher or lower operating temperatures we offer recommendations for special lubricants.

Materials

Ceramics

Ceramic components are increasingly used in planetary gears, as they can significantly improve the wear characteristics of critical components.

This results in:

- Longer service life
- Higher continuous torques
- Higher intermittent torques
- Higher input speeds

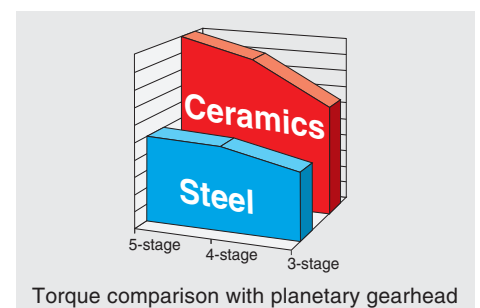
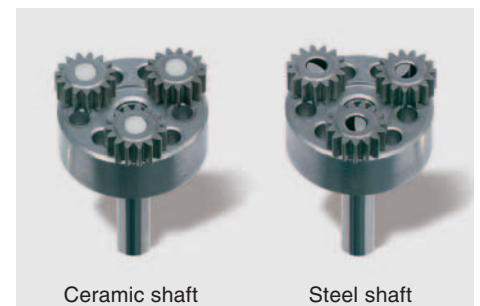

Plastic

Favorably priced and yet compact drives can be realized with plastic gears. The mechanical load is slightly smaller than that of metal designs, however, it is significantly higher than that of spur gears.